INSTRUCTION MANUAL

SOIL TEMPERATURE HUMIDITY TRANSMITTER

TYPE RS485

JXBS-3001-TR

VER1.1

I BRIEF INTRODUCTION

1.1 Product Overview

The soil moisture temperature sensor is suitable for soil temperature and moisture measurement. Compared with the German original high-precision sensor and the actual soil drying and weighing method, the soil moisture temperature sensor has high accuracy, fast response and stable output. Less affected by soil salt content, suitable for all kinds of soil. Can be buried in soil for a long time, resistant to long-term electrolysis, corrosion resistance, vacuum potting, completely waterproof.

1.2 Measurement Parameters and Hardware Parameters

PARAMETERS	CONTENT	PARAMETERS	CONTENT
POWER SUPPLY	12-24V DC	TEMPERATURE MEASUREMENT RANGE	-40°C-80°C
MOISTURE MEASUREMENT RANGE	0-100%	TEMPERATURE ACCURACY	±0.5°C
RANGE	-45°C-115°C	OUTPUT SIGNAL	RS485
MOISTURE ACCURACY	± 3% in the 0-53% range; ± 5% in the range of 53-100%	INSTALLATION METHOD	All buried or probes are inserted into the measured medium
RESPONSE TIME	<1s	PROTECTION LEVEL	IP68

POWER CONSUMPTION	\leq	0.15W	WORKING RANGE	PRESSURE	0.9-1.1atm
		(@12V DC ,			
		25°C)			

1.3 System frame Diagram

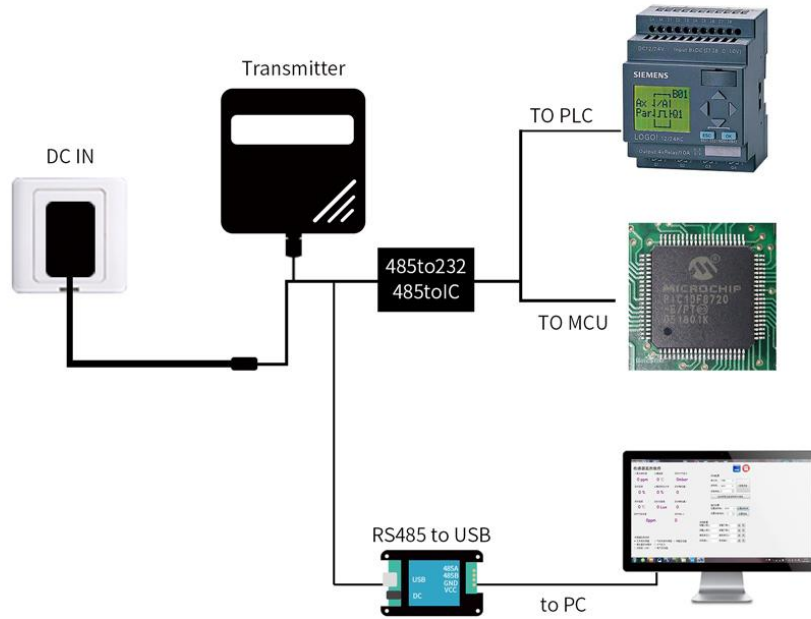

FIGURE 1 SINGLE-ENDED

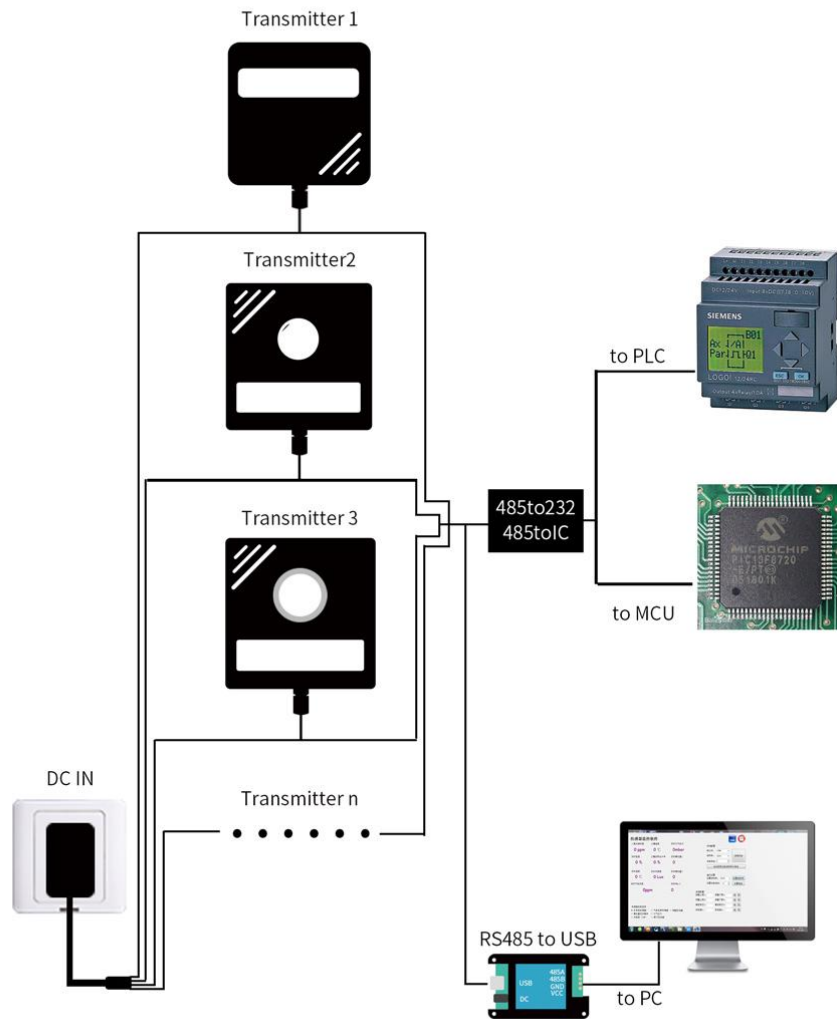

FIGURE 2 MUTIPLE-ENDED

II HARDWARE CONNECTIONS

2.1 CHECKING BEFORE INSTALLATION

Check the list of devices before installation:

TABLE 1 List of Devices

Name	Number
THE SENSOR DEVICE	1
12V POWER ADAPTER (Optional)	1
WARRANTY CARD / CERTIFICATE	1
THE USB TO 485 DEVICE(Optional)	1

2.2 Interface Description

Before you wiring and use, please read this article in detail, Improper use may result in irreversible damage to the product.



TABLE 2 Wiring Sequence

	Line Color	Description
Power	Brown	Power supply Positive (12-24V DC)
	Black	Power supply Negative
Communication	Yellow (Gray)	485-A
	Blue	485-B

We provide default cable length of 1.5 meters, you can extend the cable yourself according to your needs.

2.3 Speed measurement method

Select a suitable measurement site, avoid the stones, ensure that the steel needle does not hit a hard object, throw the topsoil at the required depth of measurement, keep the underlying soil tight, grip the sensor vertically into the soil, insert It is not allowed to shake right and left. It is recommended to measure multiple times within a small range of a measurement point to obtain the average value.

2.4 Buried method

Dig a pit with a diameter of >20 cm vertically and insert the sensor steel needle horizontally into the pit wall at a given depth. After the pit is buried tightly and stable for a period of time, measurement and recording can be performed for days, months, or even longer.

2.5 Precautions

- 1, Steel needle must be fully inserted into the soil.
2. Avoid direct sunlight on the sensor and cause excessive temperature. Use caution in the field against lightning strikes.
- 3, Do not violently bend the steel needle, do not force pull the sensor leads, do not beat or violently hit the sensor.
- 4, The sensor protection grade IP68, the sensor can be soaked in water.
- 5, Due to the presence of radio frequency electromagnetic radiation in the air, it should not be in a state of power in the air for a long time.

III CONFIGURATION TOOL

INSTALLATION AND USE

We provide **CONFIGURATION TOOL** , which can be easily used to test our sensor device.

3.1 Sensor Access Computer

Transmitter can be connected to PC with the RS485 to USB adapter. You can check the COM port number through Device Manager (right click My Computer).

3.2 How To Use Configuration Tool

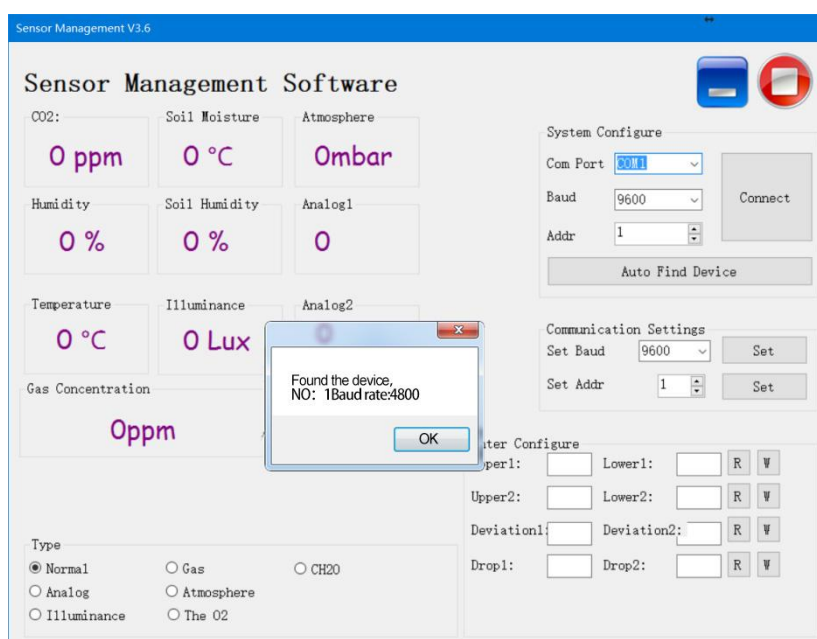

Please note that this software can only test one device at the same time. After connecting the physical device, click the **CONNECT** button to read the information. In the UNCONNECT state, you can modify BAUD and ADDR in COMMUNICATION

SETTINGS.

Under the software, different check boxes can be selected according to different situations. For example, you can choose the GAS option to test the RS485 OXYGEN SENSOR , you can choose the NORMAL option to test the RS485 TEMPERATURE AND HUMIDITY SENSOR .

IV COMMUNICATION PROTOCOL

4.1 Communication Basic Parameters

TABLE 3 Communication Basic Parameters

PARAMETERS	CONTENT
Protocol	Modbus RTU
Data bits	8 bit
Parity bit	No
Stop bit	1 bit
Error checking	CRC (redundant loop code)
Baud rate	2400 bps/ 4800 bps/ 9600 bps can be set factory defaults to 9600 bps

For more information about **MODBUS RTU** please visit the website "www.modbus.org".

4.2 Register Address

Register Address	Plc Configuration Address	Content	Operation
0002H	40003	Soil humidity(unit 0.1%RH)	Read-Only
0003H	40004	Soil temperature(unit 0.1°C)	Read-Only
0100H	40101	Device Address (0-252)	R/W
0101H	40102	Baud Rate (2400/4800/9600)	R/W

TABLE 4 Register Address

4.3 Communication example

4.3.1 Read Device Address 0x01's Soil Temperature And Humidity

TABLE 5 Inquiry Frame

Address Code	Function Code	Start Address	Data Length	CRC_L	CRC_H
0x01	0x03	0x00 0x02	0x00 0x02	0x65	0xCB

TABLE 6 Answer Frames

Address Code	Function Code	Number Of Valid Bytes	Humidity Value	Temperature Value	CRC_L	CRC_H
0x01	0x03	0x04	0x02	0xFF	0x5A	0x3D
			0x92	0x9B		

Soil temperature :

FF9BH (hexadecimal) = -101 => temperature = -10.1°C

Soil humidity:

292H(hexadecimal) = 658 => humidity = 65.8%RH

4.3.2 Read Device Address 0x01's Soil Humidity Value

TABLE 7 Inquiry Frame

Address Code	Function Code	Start Address	Data Length	CRC_L	CRC_H
0x01	0x03	0x00	0x00	0X25	0xCA
		0x02	0x01		

TABLE 8 Answer Frame

Address Code	Function Code	Number Of Bytes	Humidity Value	CRC_L	CRC_H
0x01	0x03	0x02	0x00	0x39	0xB3
			0x4A		

Soil humidity:

4AH(hexadecimal) = 74 => humidity = 7.4%RH